



VMDIC404 - 4 INPUT / 4 RELAY OUTPUT VEGA DIN RAIL MULTI-MODULE

GENERAL DESCRIPTION

The Vega DIN rail multi-module series is a family of interface devices permitting the monitoring and control of auxiliary devices. Vega DIN rail multi-modules are loop powered devices and operate according to the Vega analogue-intelligent protocol; this particular model is meant to be installed on standard "top hat" DIN rails. A channel is a multi-module's sub-device through which monitoring and control of analogue-loop-extraneous auxiliary devices is exerted by the analogue control panel. DIN rail multi-modules are, by a matter of fact, multi-channel devices.

TECHNICAL SPECIFICATIONS **

Compatible communication / control protocol	Vega analogue-intelligent protocol
Vega protocol voltage range	from 4 V to 42 V
Device operative voltage range *	from 18 V to 40 V
Standby current consumption	500 µA at 24 V
Supervised input and supervised output "end of line" resistor recommend value (R _{EOL})	27 KΩ
Supervised input auxiliary device's series resistor to the switch recommended value (R _{SW})	10 KΩ
Operating temperature range	from -10 °C to +55 °C
Humidity	from 5 RH% to 85 RH%
IP rating	30
Dimensions	120 x 100 x 20 mm
Weight	100 grams
Compatible DIN rail type	Top hat rail type, 35 x 7.5 / 35 x 15 mm
Applicable wire gauge range	from 0.5 mm ² to 2.5 mm ²

*Product operates down to 15 V, but without LED indication.
**Check latest version of document TDS-VMULT for further data, obtainable from your supplier.

SHORT-CIRCUIT ISOLATOR

The DIN rail multi-module has a built-in bidirectional isolator designed to provide short circuit isolation and functional protection features for the analogue-intelligent loop. When activated, the isolator will "cut out" the adjacent loop's section where the short occurred; on the other hand, all functions of the devices situated on opposite loop's section of the DIN rail multi-module will be unaffected and operate normally.

When the short is removed, the DIN rail multi-module restores power to the isolated loop's section and its devices.

LED INDICATORS

DIN rail multi-modules are equipped with two LED indicators: one is dedicated to the input channels and the second one is dedicated to the output channels; these two indicators can be seen in the front of the device, behind the transparent window, when the module is installed on the DIN rail. Whether the specific indicator indicates the input or the output channels, this is indicated on the side label of the device, together with the terminal block's schemes.

LED indications can be green, red or amber.

When all channels are in normal condition, the status of the first input channel is signalled on the input LED and the status of the first output channel is signalled on the output LED.

If one channel alters its condition (fault or alarm), then the related LED signals the condition of it. If more than one channel is in a not-normal condition, then the first one, in the address sequence, is signalled.

ADDRESSING

DIN rail multi-modules are analogue-addressable devices. Each DIN rail multi-module type can be assigned more than one address, this depends by the choices made by the installer of the fire security system and its design. If installed on a loop, the DIN rail multi-module must be assigned at least one address, with a value ranging from 1 to 240, which corresponds to the first input channel that is always active and cannot be disabled; all the other ones can be activated or deactivated by the installer, depending on his needs, from the control panel (if it has been implemented with such control feature); each DIN rail multi-module takes up to 8 addresses sequentially and no inactive gaps are allowed between two active addresses. Similarly to every Vega device, each active channel can be controlled by the control panel and must have a unique address. Automatic addressing can be performed on this kind of devices (consult the analogue-intelligent auto-addressing feature described on the related application notes).

Alternatively to control panel's addressing and management, the first address of DIN rail multi-modules can be set by using a special hand-held programming unit; for more information about manual addressing, please, refer to the programming unit's instruction manual.

NOTE: DIN rail multi-modules can hold up to 8 active addresses. The address assigned by the programmer always relates to the input channel; the consecutive addresses are automatically assigned to the remaining active channels.

WIRING THE DIN RAIL MULTI-MODULE

The DIN rail multi-module must be:

- connected to the analogue loop, as any other analogue device
- connected to the monitored and/or controlled auxiliary device (or devices).

In picture 1 are illustrated the terminal block's schemes of the various types of DIN multi-modules.

Picture 1 gives, also, the wiring scheme for the loop terminal block set; the wiring scheme for the loop is common to all DIN rail multi-modules devices.

THE SUPERVISED INPUT CHANNEL AND ITS WIRING

This channel provides monitoring of normally open contact fire alarm devices (picture 2). This channel is capable of supervising an adequate "end of line" resistor (R_{EOL}) fitted to its terminals; purpose of this supervision is to distinguish between the following conditions:

- Normal condition.
- Alarm condition.
- Short circuit fault condition.
- Open circuit fault condition.

R_{SW} guarantees the alarm current when the switch is closed.

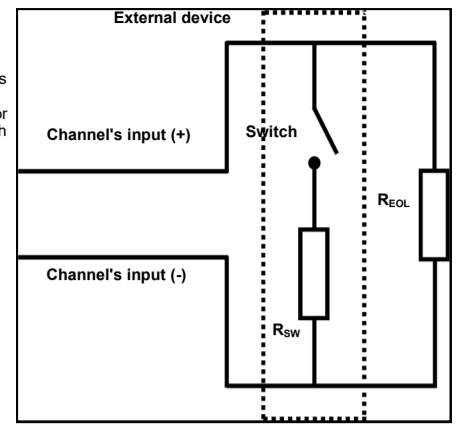

Picture 2 - supervised input channel's wiring

THE RELAY OUTPUT CHANNEL AND ITS WIRING

This output channel provides relay's double pole contacts changeover for the control of auxiliary devices (picture 3 illustrates a wiring example). This non-supervised relay output is controlled and can be switched over by the control panel.

This channel type is characterized by 3 terminals:

- C: "common" terminal
- NC: "normally closed" terminal
- NO: "normally open" terminal

By default, C is switched over the NC terminal; when activated, C is switched over the NO terminal.

Please note that due to the non supervised nature of this output, only technologic devices can be connected to it (fire shutters hold / release devices and so on).

TESTING

In order to try out the functionality of the installed DIN rail multi-module, the following tests must be performed:

All active output channels - alarm test: trigger an alarm condition on the control panel (by a call-point or sensor in the installed system); the control panel will activate or switch-over the DIN rail multi-module's output (or outputs).

All active input channels - alarm test: activate the external device: the control panel must trigger a system alarm.

All active supervised input and output channels - fault tests: generate open and short circuit conditions on the supervised channel's loops: the control panel must signal one or more fault conditions.

After each test, the device must be reset by the specific command on the control panel (see the RESET paragraph).

All devices must be tested after installation and, successively, on a periodic basis.

RESET

To reset the DIN rail multi-module from an alarmed or a fault condition, it is necessary to:

- solve the cause of the abnormal condition
- reset the system from the control panel.

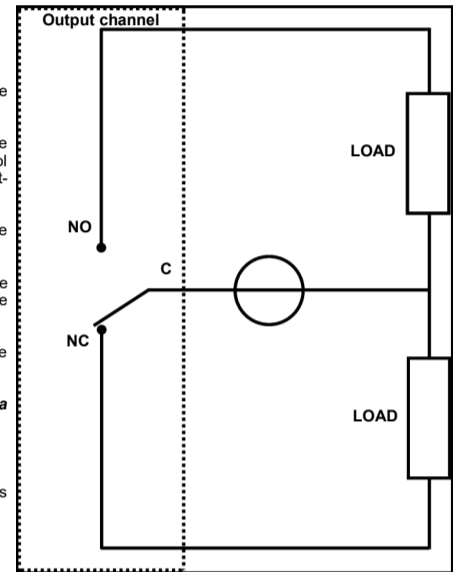

Picture 3 - Relay output channel's wiring

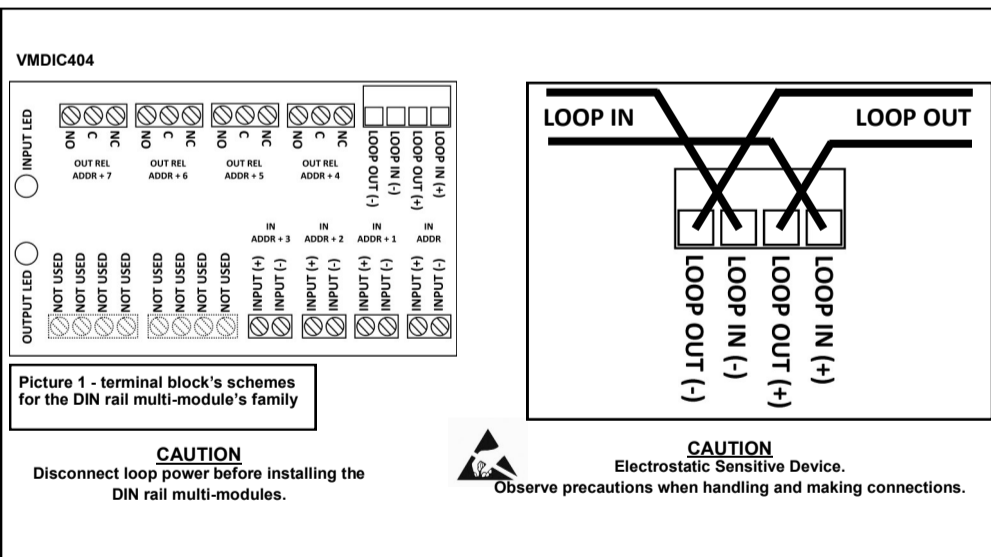

Picture 1 - terminal block's schemes for the DIN rail multi-module's family

CAUTION
Disconnect loop power before installing the DIN rail multi-modules.



CAUTION
Electrostatic Sensitive Device.
Observe precautions when handling and making connections.

WARNINGS AND LIMITATIONS

Our devices use high quality electronic components and plastic materials that are highly resistant to environmental deterioration. However, after 10 years of continuous operation, it is advisable to replace the devices in order to minimize the risk of reduced performance caused by external factors. Ensure that this device is only used with compatible control panels. Detection systems must be checked, serviced and maintained on a regular basis to confirm correct operation. Smoke sensors may respond differently to various kinds of smoke particles, thus application advice should be sought for special risks. Sensors cannot respond correctly if barriers exist between them and the fire location and may be affected by special environmental conditions. Refer to and follow national codes of practice and other internationally recognized fire engineering standards. Appropriate risk assessment should be carried out initially to determine correct design criteria and updated periodically.

WARRANTY

All devices are supplied with the benefit of a limited 5 years warranty relating to faulty materials or manufacturing defects, effective from the production date indicated on each product. This warranty is invalidated by mechanical or electrical damage caused in the field by incorrect handling or usage. Product must be returned via your authorized supplier for repair or replacement together with full information on any problem identified. Full details on our warranty and product's returns policy can be obtained upon request.

0051	8504
11	22
VE1510CPR	VE1510UK
ARGUS SECURITY S.R.L. Via del Canneto, 14 34015 Muggia (TS) Italy	
EN 54-17:2005 EN 54-18:2005	
VMDIC404	
For use in compatible fire detection and alarm system	