

## DATASHEET

# WIRELESS BLACK HEAT DETECTOR

TW-DT-01/BL

**TAURUS**  
By ARGUS SECURITY 

The TW-DT-01/BL Wireless Black Heat Detector is the latest in wireless heat detector technology. The detector is a fully intelligent device designed to give the best possible warning of a fire condition in locations where smoke detection technology is not suitable. The device is capable of being configured as either a high temperature or rate of rise device type. The well-proven adaptive radio signal processing algorithms ensure the highest levels of life safety and system reliability are achieved. An in-built magnet test allows easy activation to verify correct functionality and response.



## KEY FEATURES

- Twin alarm LEDs for 360° visibility
- Programmable for rate of rise (A1R) or high temperature (BS)
- Bi-directional wireless communication
- Can be used with Taurus addressable and conventional translators
- 22 pairs of field channels
- Dual channel redundancy
- Long communication range ( $\cong 1$  km in open air)
- 10 year battery life
- Utilises standard low cost lithium battery technology
- Device identification tab
- Security screw to prevent tampering and unwanted removal
- Easy scan & link programming option
- 3rd party approval to EN54-5 and EN54-25
- 5 year product warranty
- Tri-colour LED

## TECHNICAL SPECIFICATION

Operating frequency range	868 – 870 MHz
Max radiated power	14dBm (25mW)
Class	Class A1R (58°C max) or Class BS high temp (78°C)
Dimensions	110mm x 70mm
Weight (without batteries)	153 g
Batteries	2x CR123A
Operating Temperature	-10°C to +55°C
Max humidity (non condensing)	95% RH
IP rating	40

## TECHNICAL INFORMATION

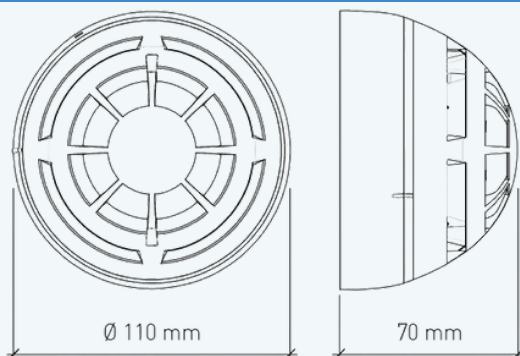

## STANDARDS & APPROVALS

- EN54-5 Class P: Heat Detectors. Point Detectors
- EN54-25: Components using radio links



### Argus Security S.r.l.

Via del Canneto, 14 – Località Vignano  
Z.I. Valle delle Noghère  
34015 Muggia (TS) Italy

T: +39-040.23.96.411  
E: info@argussecurity.it  
[www.argussecurity.it](http://www.argussecurity.it)

  
A Halma company

# DATASHEET

## WIRELESS BLACK HEAT DETECTOR

### BASE COMPATIBILITY

---

This device is supplied with a standard base and is compatible with the following sounder bases:

- TAU-BS-01/BL Wireless Black Sounder Base
- TAU-BSB-23W-01/BL Wireless Black Sounder VAD Base (White Flash) (EN54-23 approved)



**Argus Security S.r.l.**

Via del Canneto, 14 – Località Vignano  
Z.I. Valle delle Noghère  
34015 Muggia (TS) Italy

T: +39-040.23.96.411  
E: [info@argussecurity.it](mailto:info@argussecurity.it)  
[www.argussecurity.it](http://www.argussecurity.it)