

DATASHEET INTELLIGENT INPUT AND OUTPUT MODULE (PLATE MOUNT)

VMIC100

The Argus module range provides an ideal solution to the monitoring and control requirements of most fire detection and alarm systems, ranging from small and simple, to large and complex. By utilising the Argus fully digital communication protocol, reliable and fast operation is achieved even when employing the impressive 240 device loop capacity. A choice of mechanical configurations provides easy integration of the units into a variety of field locations. The VMIC100 is mounted on a standard faceplate and can be used with a surface back box or flush mounted and provides the capability to remotely monitor a single circuit and control a single ancillary circuit using external power. Both input and output circuits are monitored for fault conditions. Bi-colour LEDs provide local indication of device status.



KEY FEATURES

- Employs the highly reliable Argus digital protocol
- Integrated short circuit isolators to protect and maintain operation
- Loop powered with very low current consumption
- Robust proven design offering operation over a wide temperature range
- Provides both a fully monitored input and output circuit
- Fast fit plug-in cable connections
- Alternate mechanical variants available to satisfy different applications
- LED status indicators for both input and output circuits
- Fits to single gang (deep) back box
- 5 year product warranty

TECHNICAL SPECIFICATION

Loop voltage range	15Vdc – 40Vdc*
Normal Standby Current	250µA @ 24Vdc
Alarm Current (1-2 red LED)	6-12mA @ 24Vdc
Dimensions	86.5 x 86.5 x 24mm (ex-back box)
Max output rating	2A @ 30Vdc
Temperature Range (no icing)	-10°C to +55°C
Max. humidity (non condensing)	95% RH
Weight	200g

*Min 18Vdc for operation of LED.

TECHNICAL INFORMATION

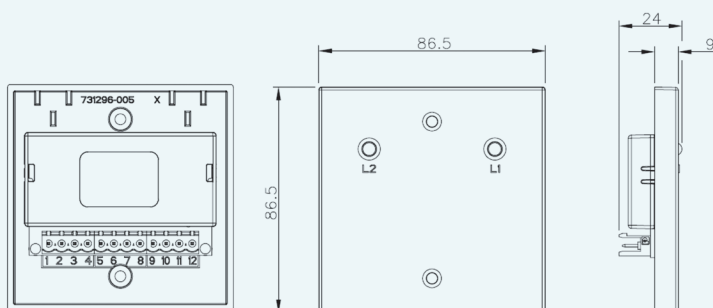

STANDARDS & APPROVALS

- EN 54-17: Short-circuit isolators
- EN 54-18: Input/output devices

