

## DATASHEET INTELLIGENT INPUT MODULE (PLATE MOUNT)

### VMI100

The Argus module range provides an ideal solution to the monitoring and control requirements of most fire detection and alarm systems, ranging from small and simple, to large and complex. By utilising the Argus fully digital communication protocol, reliable and fast operation is achieved even when employing the impressive 240 device loop capacity. A choice of mechanical configurations provides easy integration of the units into a variety of field locations. The VMI100 is mounted on a standard faceplate and can be used with a surface back box or flush mounted and provides the capability to remotely monitor a single circuit which is monitored for fault and alarm condition, a bi-colour LED provides local indication of device status.



### KEY FEATURES

- Employs the highly reliable Argus digital protocol
- Integrated short circuit isolators to protect and maintain operation
- Loop powered with very low current consumption
- Robust proven design offering operation over a wide temperature range
- Single monitored input circuit
- Alternate mechanical variants available to satisfy different applications
- Compatible with wired loops that also support Argus wireless system devices
- Fits to BS Back Box

### TECHNICAL SPECIFICATION

Loop voltage range	15 – 40Vdc*
Normal Standby Current	120µA @ 24Vdc
Alarm Current (1 red LED)	6mA @ 24Vdc
Dimensions	86.5 x 86.5 x 24mm (ex-back box)
Weight	200g
Temperature Range (no icing)	-10°C to +55°C
Max. humidity (non condensing)	95% RH

\*Min 18Vdc for operation of LED.

### TECHNICAL INFORMATION

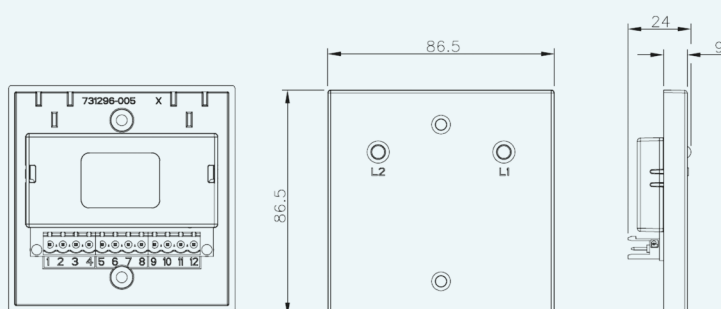

### STANDARDS & APPROVALS

- EN 54-17: Short-circuit isolators
- EN 54-18: Input/output devices

