

## PRODUCT DATASHEET

### UA-BCW-H65

## DEEP BASE HOUSING

The UA-BCW-H65 deep base housing has been specially designed to assist the installer when mounting point detection devices into difficult and harsh environments. Its integrated device cowl diverts excess water away from the detection device allowing the device to be mounted onto surfaces where higher than normal levels of condensation or moisture are present.

The unit has pre-formed conduit entry knockouts on four sides, allowing for simple and professional surface installation. The unit is compatible with the entire Argus wired and wireless point detection range.



## KEY FEATURES

- M16 and M20 Pre cut conduit and gland entry points to sides and base
- External removable fixing lugs allow base to be mounted while maintaining the maximum protection from water ingress
- Base design compatible with all Argus wired and wireless detectors\*
- Deep design directs condensation droplets from ceiling away from the detectors and provides additional protection against water and air movement
- Full screw-kit provided

\*Not suitable for the discontinued Sagittarius detectors

## TECHNICAL INFORMATION

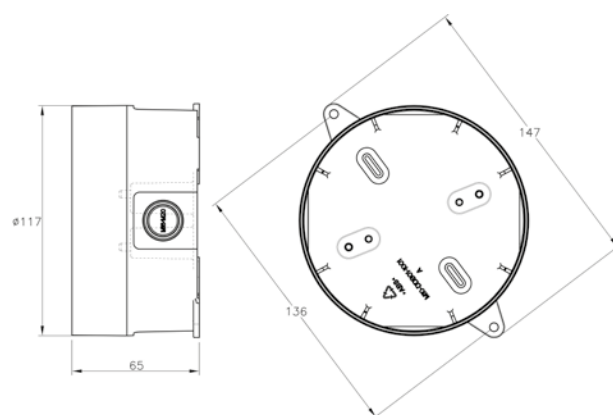

## TECHNICAL SPECIFICATION

- |                                  |  |
|----------------------------------|--|
| ■ Compatibility                  | All detectors in the current Argus wired and wireless range* |
| ■ Dimensions                     | 117mm x 65 mm  |
| ■ Weight                         | 87g  |
| ■ Temperature Range (no icing)   | -10°C to +55°C   |
| ■ Max. humidity (non condensing) | 95% RH   |
| ■ Conduit entry size             | 4 no. x 16mm - 20mm  |

## STANDARDS & APPROVALS