

## DATASHEET WIRELESS CLASS P HEAT DETECTOR

TW-DT-01

The TW-DT-01 Taurus wireless heat detector is the latest in wireless heat detector technology. The detector is a fully intelligent device designed to give the best possible warning of a fire condition in locations where smoke detection technology is not suitable. The device is capable of being configured as either a high temperature or rate of rise device type. The well-proven adaptive radio signal processing algorithms ensure the highest levels of life safety and system reliability are achieved. An in-built magnet test allows easy activation to verify correct functionality and response.



### KEY FEATURES

- Twin alarm LEDs for 360° visibility
- Programmable for rate of rise (A1R) or high temperature (BS)
- Bi-directional wireless communication
- Can be used with Taurus addressable and conventional translators
- 22 pairs of field channels
- Dual channel redundancy
- Long communication range ( $\cong 1$  km in open air)
- 10 year battery life
- Utilises standard low cost lithium battery technology
- Device identification tab
- Security screw to prevent tampering and unwanted removal
- Easy scan & link programming option
- 3rd party approval to EN54-5 and EN54-25
- 5 year product warranty
- Tri-colour LED

### TECHNICAL SPECIFICATION

Operating frequency range	868 – 870 MHz
Max radiated power	14dBm (25mW)
Class	Class A1R (58°C max) or Class BS high temp (78°C)
Dimensions	110mm x 70mm
Weight (without batteries)	153 g
Batteries	2x CR123A
Operating Temperature	-10°C to +55°C
Max humidity (non condensing)	95% RH
IP rating	40

### TECHNICAL INFORMATION

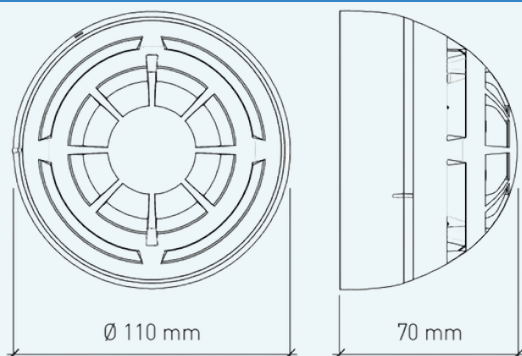

### STANDARDS & APPROVALS

- EN54-5 Class P: Heat detectors - Point heat detectors
- EN54-25: Components using radio links



# DATASHEET

## WIRELESS CLASS P HEAT DETECTOR

### BASE COMPATIBILITY

---

This device is supplied with a standard base and is compatible with the following sounder bases:

- TW-BS-01 Wireless Sounder Base
- TW-BSB-23W-01 Wireless Sounder Base + beacon white light  
(EN-54-23 approved)
- TW-BSB-23R-01 Wireless Sounder Base + beacon red light  
(EN-54-23 approved)

