

## WIRELESS SOUNDER BASE

**Orama group**

### SGRBS100/L

The SGRBS100/L Wireless Sounder Base unit is an aesthetically pleasing and cost effective alternative to traditional wall mounted sounder units where visual impact is important. Each unit has an integral moulded base for mounting an Argus wireless detector or a sounder cover if a detector is not required. The unit has as standard 32 recognised sounder tones and 3 levels of volume adjustment, all of which can be easily configured on site. Powered by standard lithium batteries and utilising well proven adaptive radio signal processing algorithms ensure the highest levels of life safety and reliability.



### KEY FEATURES

- 3rd party Approved
- Bi-directional wireless communication
- 5 year product warranty
- Utilises dual low cost standard lithium batteries
- Choice of 32 recognised tones
- Compatible with all Argus translators and expanders
- Integral detector base
- Red and white cover options
- 3 volume levels
- 3 year expected battery life

### TECHNICAL SPECIFICATION

Operating frequency range	868 - 870 MHz
Operating frequency channels	7
Communication range with the Translator or Expander Module	≤ 150m (in open space)
IP rating	20 (Type A for indoor use only)
Sound Output (typical)	70-95dBA (tone dependant)
Number of Tones	32
Dimensions	116 mm x 51 mm
Weight (without batteries)	150g
Primary battery	CR123A (3 V & 1.2 Ah)
Secondary battery	CR123A (3 V & 1.2 Ah)
Primary battery lifespan (typical)	≥ 3 years
Secondary battery lifespan (typical)	≥ 2 months
Operating Temperature	-10°C to +55°C
Max humidity (non condensing)	95% RH

### TECHNICAL INFORMATION

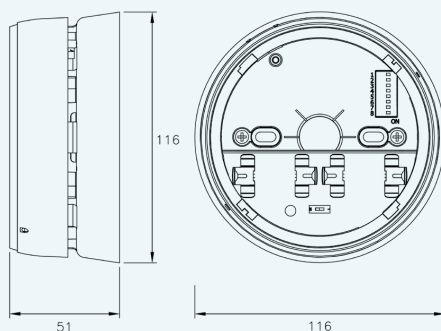

### STANDARDS & APPROVALS

- EN 54-3: Fire alarm devices - Sounders
- EN 54-25: Components using radio links

