

DATASHEET WIRELESS SINGLE CHANNEL INPUT MODULE

SGMI200

The Argus SGMI200 Wireless Module has been designed to provide a convenient and cost effective solution for monitoring third party equipment. The unit has a single fully monitored input circuit which allows simple integration of third party equipment with the fire system. The unit is fully compatible with all Argus Translator and Expander modules and the well proven adaptive radio signal processing algorithms ensure the highest levels of life safety and system reliability.



KEY FEATURES

- 3rd party Approval to EN 54-25 and EN 54-18
- 5 year product warranty
- 3 year expected battery life
- Self optimising wireless frequency and amplitude algorithms
- Bi Directional wireless communication
- Fully intelligent
- Input circuits are fully monitored for alarm and fault conditions
- Utilises dual low cost lithium battery

TECHNICAL SPECIFICATION

Operating frequency range	868 - 870 MHz
Max radiated power	5dBm (3mW)
Radio signal modulation type	FSK
Operating frequency channels	7
Communication range with the translator or the expander	≤ 150 m (in open space)
Max humidity (non condensing)	95% RH
Cable entry knockout holes	6 x M16/20
Applicable wire gauge range	0.5 mm ² to 2.5 mm ²
Weight (without batteries)	190 g
Primary battery	CR123A (3 V & 1.2 Ah)
Secondary battery	CR2032 (3 V & 0.24 Ah)
Primary battery life (typical)	5 years
Secondary battery life (typical)	2 months
Operating temperature range (no icing)	2 -10°C - +55°C

TECHNICAL INFORMATION

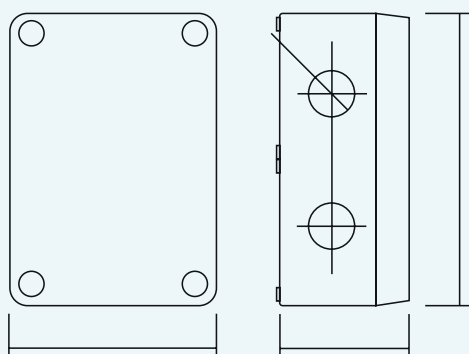

STANDARDS & APPROVALS

- EN 54-18: Input/output devices
- EN 54-25: Components using radio links

