

WIRELESS CLASS P HEAT DETECTOR

The TW-DT-01 Taurus wireless heat detector is the latest in wireless heat detector technology. The detector is a fully intelligent device designed to give the best possible warning of a fire condition in locations where smoke detection technology is not suitable. The device is capable of being configured as either a high temperature or rate of rise device type. The well-proven adaptive radio signal processing algorithms ensure the highest levels of life safety and system reliability are achieved. An in-built magnet test allows easy activation to verify correct functionality and response.



KEY FEATURES

- Twin alarm LEDs for 360° visibility
- Programmable for rate of rise (A1R) or high temperature (BS)
- Bi-directional wireless communication
- Can be used with Taurus addressable and conventional translators
- 22 pairs of field channels
- Dual channel redundancy
- Long communication range ($\cong 1$ km in open air)
- 10 year battery life
- Utilises standard low cost lithium battery technology
- Device identification tab
- Security screw to prevent tampering and unwanted removal
- Easy scan & link programming option
- 3rd party approved
- 5 year product warranty
- Tri-coloured LED

TECHNICAL INFORMATION

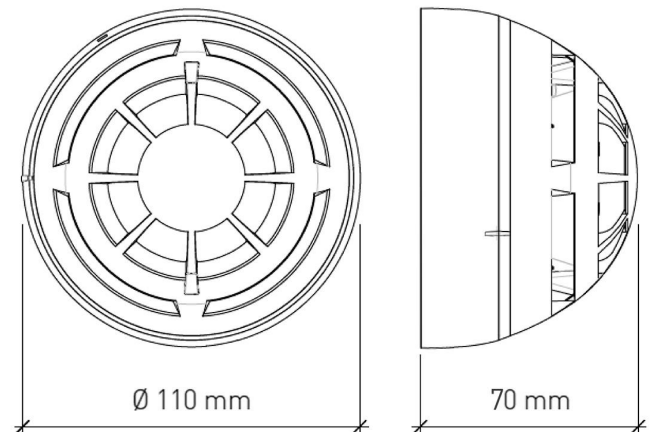

TECHNICAL SPECIFICATION

Operating frequency range	868 – 870 MHz
Max radiated power	14dBm (25mW)
Class A1R (58°C max) or Class BS high temp (78°C)	
Dimensions	110mm x 70mm
Weight (without batteries)	153 g
Batteries	2x CR123A
Operating Temperature	-10°C to +55°C
Max humidity (non condensing)	95% RH
IP rating	40

STANDARDS & APPROVALS

- EN54-5 Class P: Heat Detectors. Point Detectors
- EN54-25: Components using radio links



0051

BASE COMPATIBILITY

This device is supplied with a standard base and is compatible with the following Argus base sounders / beacons :

- TW-BS-01 Wireless Sounder Base
- TW-BSB-23W-01 Wireless Sounder Bases+ beacon white light (EN-54 23 approved)
- TW-BSB-23R-01 Wireless Sounder Bases+ beacon red light (EN-54 23 approved)

ORDER CODE

TW-DT-01

TAURUS WIRELESS CLASS P HEAT DETECTOR

Check if this document is up to date

Argus Security Srl, Via del Canneto, 14, 34015 Muggia, (TS), Italia T: +39-040.23.96.411, E: info@argussecurity.it, W: www.argussecurity.it

As our policy is one of constant product improvement the right is therefore reserved to modify product specifications without prior notice.